



# STAR-MAX<sup>®</sup> GAS STOCK POT RANGE

## Model 601SPRD

### Features/Benefits:

- ★ Star Max stock pot range is designed for the most demanding foodservice applications and delivers years of maintenance free operation.
- ★ High performance 110,000 BTUs (90,000 LP) two-piece ring-type cast iron burner provide maximum cooking performance.
- ★ Heavy-duty one-piece cast iron grate handles a variety of pots and stands up to constant use.
- ★ Standing pilot for easy ignition.
- ★ Manual on/off control valve has 1/4 turn for easy temperature control.
- ★ Gas convertible in the field with conversion kit supplied with each stock pot range. Units are shipped Natural Gas.
- ★ Cool to the touch stainless steel bull nose front provides knob protection and comfortable work zone.
- ★ Removable crumb tray for easy cleaning.
- ★ Heavy-duty 6" legs with a 1-1/2" adjustment to fit any size operation.



Model 601SPRD

### Applications:

Star-Max stock pot range is designed for years of maintenance free operation and reliable cooking performance. Use the stock pot range to cook, heat or sauté your menu items to perfection.

### Quality Construction:

Star-Max stock pot range is constructed of stainless steel front with attractive polycarbonate trim, a stainless steel bull nose and aluminized steel drip pan for long lasting durability. Units are shipped from the factory for operation on natural gas. Propane gas conversion can be accomplished in the field by changing orifices (supplied with units) and regulator setting.

### Warranty:

Star-Max stock pot range is covered by Star's one year parts and labor warranty.





## STAR-MAX® GAS STOCK POT RANGE Model 601SPRD

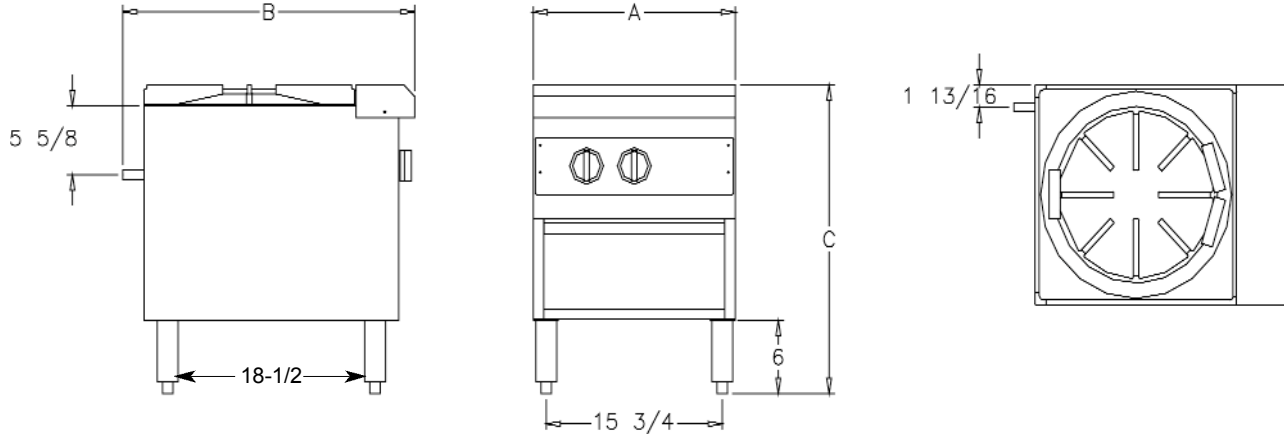

### Specifications

Model No.	Dimensions			Cooking Surface Height Inches (cm)	Approximate Weight	
	(A) Width Inches (cm)	(B) Depth Inches (cm)	(C) Height Inches (cm)		Installed lbs. (kg)	Shipping lbs. (kg)
601SPRD	18-1/8 (46.0)	26 (66.0)	25-11/32 (64.0)	25-11/32 (64.0)	123 (55.9)	140 (63.6)

6" (15.2 cm) legs with 1-1/2" (3.8 cm) adjustment

### Gas Data

Model No.	Type Gas	BTU Rating	Type Connections
601SPRD	Natural/Propane	110,000 Natural 90,000 Propane	3/4" (1.9 cm) N.P.T. Male

### Typical Specifications

Gas stock pot range is constructed of 16 gauge welded aluminized steel. Unit has a stainless steel front panel with black polycarbonate trim and a stainless steel bull nose that provides knob protection. Unit has a full width aluminized steel drip pan, heavy duty one-piece cast iron top grate, two-piece ring type heavy-duty 110,000 BTU (90,000 LP) burner, 2 standing pilots, 1/4 turn on-off manual control valves and convertible pressure regulator, and 6" adjustable legs. Unit operates on natural or propane gas. Stock Pot Range is AGA certified and NSF and CGA listed. Printed in the U.S.A.

Due to periodic changes in designs, methods, procedures, policies and regulations, the specifications contained in this sheet are subject to change without notice. While Star Manufacturing exercises good faith efforts to provide information that is accurate, we are not responsible for errors or omissions in information provided or conclusions reached as a result of using the specifications. By using the information provided, the user assumes all risks in connection with such use.

Star Manufacturing International Inc. - 10 Sunnen Drive - P.O. Box 430129 - St. Louis, MO 63143-3800

Phone: (800) 264-7827 - FAX: (800) 264-6666 - [www.star-mfg.com](http://www.star-mfg.com)